

Fig. 14-107 Fixture for Centering Connecting Rod. (1) Draw details using decimal dimensions, if assigned. (2) Draw assembly. (See also Figs. 14-108 and 14-109.)

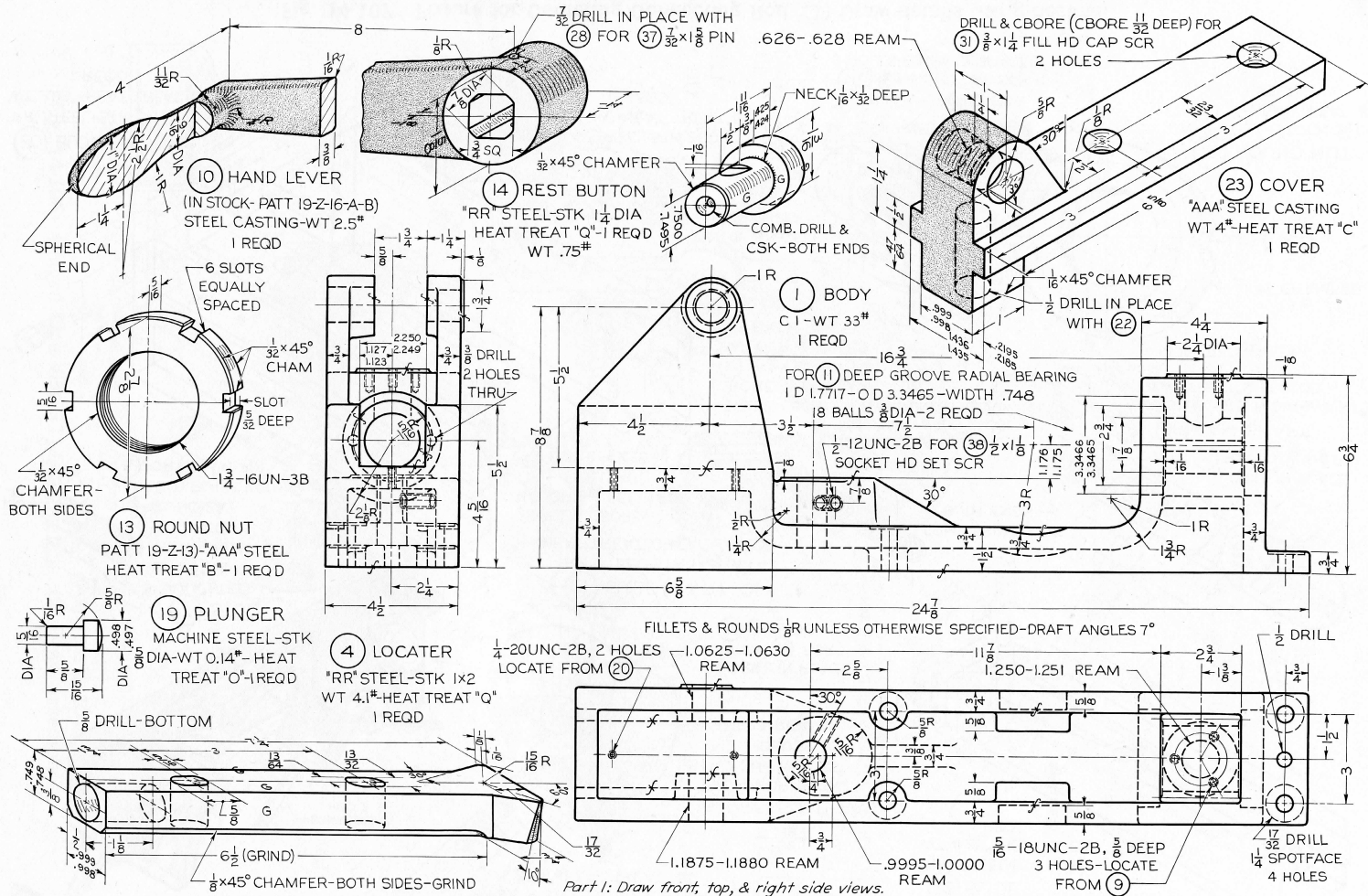

Fig. 14-108 Fixture for Centering Connecting Rod (Continued). See Fig. 14-107 for instructions.

