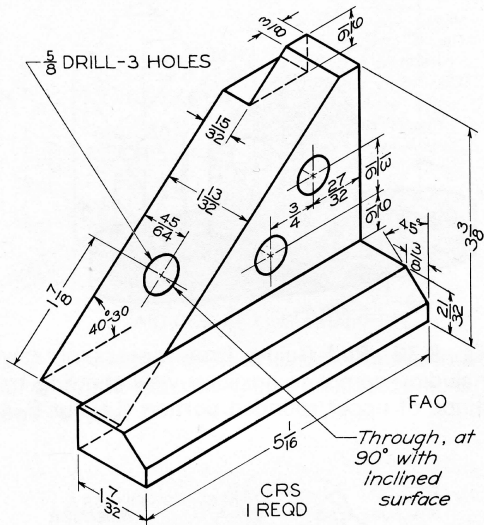

**Fig. 8-42 Tool Holder Slide.** Draw given views, and add complete auxiliary view showing true curvature of slot on bottom (Layout B-4).



**Fig. 8-43 Adjuster Block.** Draw necessary views, including complete auxiliary view showing true shape of inclined surface (Layout B-4).



