

Fig. 6-113 Feed Shaft Bracket.

Given: Front and top views.

Required: Front, top, and right-side views, half size (Layout B-3).

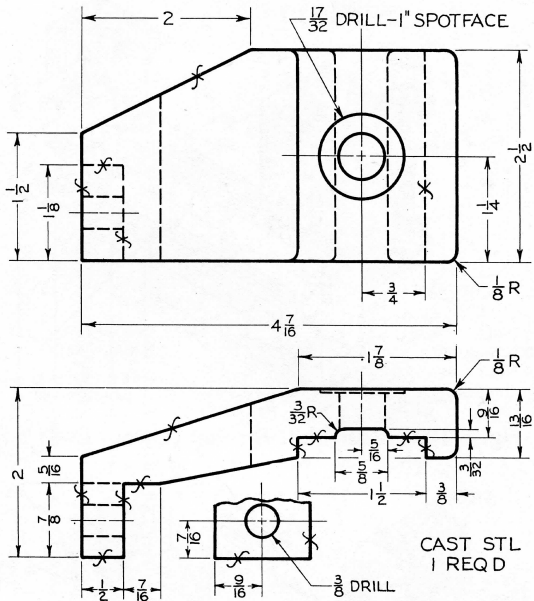

Fig. 6-114 Trip Lever.

Given: Front, top, and partial side views.

Required: Front, bottom, and left-side views, drawn completely (Layout B-3).

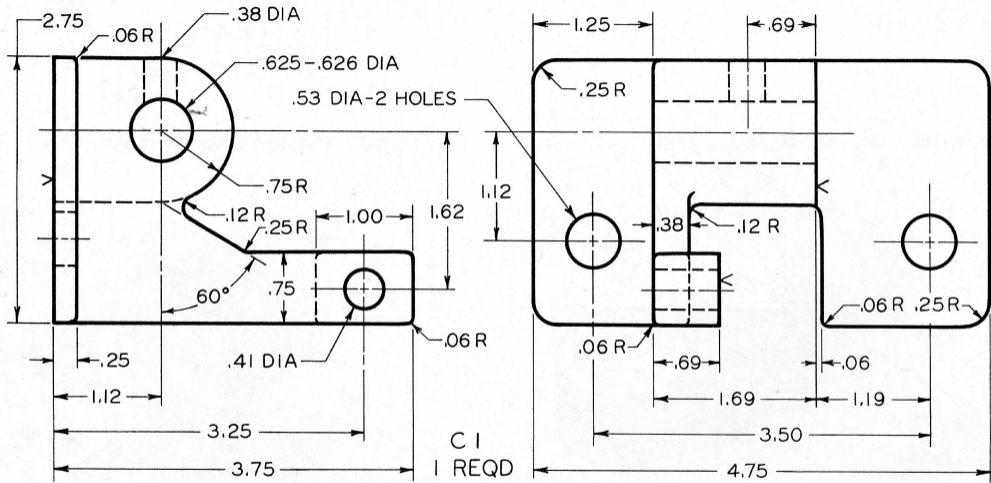

Fig. 6-115 Knurl Bracket Bearing.

Given: Front and left-side views.

Required: Take front as top view on new drawing, and add front and right-side views (Layout B-3).