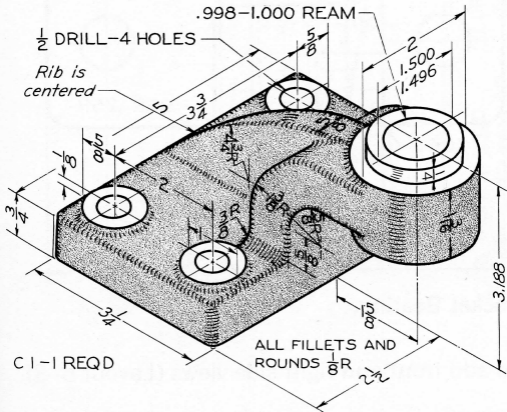

**Fig. 6-109 Ejector Base (Layout C-4).\***





**Fig. 6-111 Offset Bearing (Layout C-4).\***

