

Fig. 6-79 Lever Hub (Layout A-3).*

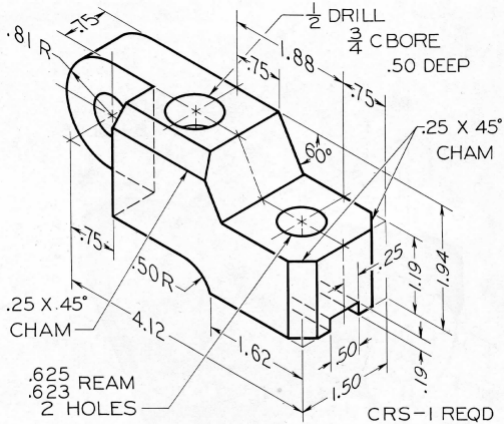

Fig. 6-80 Vibrator Arm (Layout A-3).*

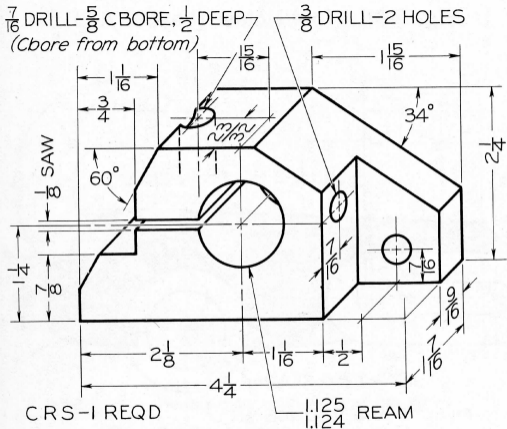

Fig. 6-81 Clutch Lever (Layout A-3).*

