

Given: Front & L S views.
 Req'd: Front, Top, & R S views.

SAE 1315
 1 REQD

Fig. 6-72 Tool Holder (Layout A-3).*

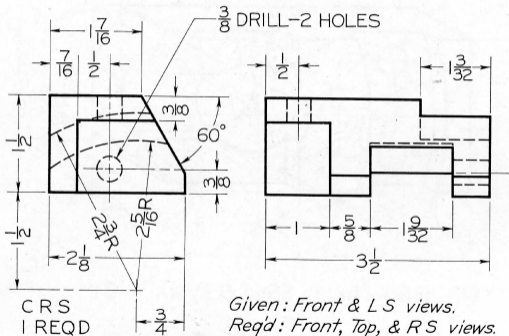
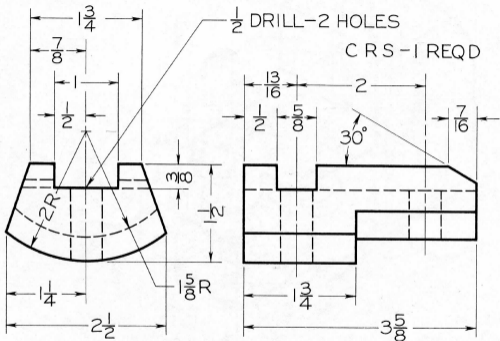

Fig. 6-73 Shifter Block (Layout A-3).*



Given: Front & L S views.

Reqd: Front, Top, & R S views.

Fig. 6-75 Cross Cam (Layout A-3).*

