

REAM FOR  $\frac{5}{16}$  DOWELS -  
2 HOLES

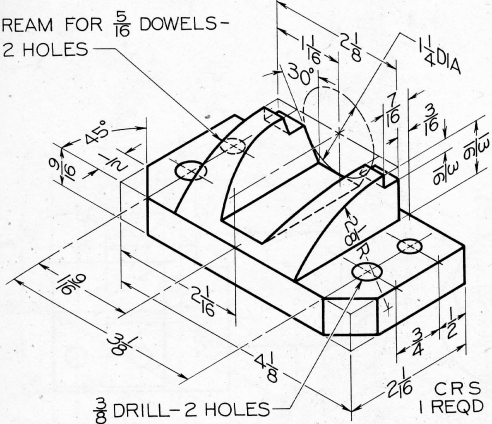

**Fig. 6-65 Locating Finger (Layout A-3).\***

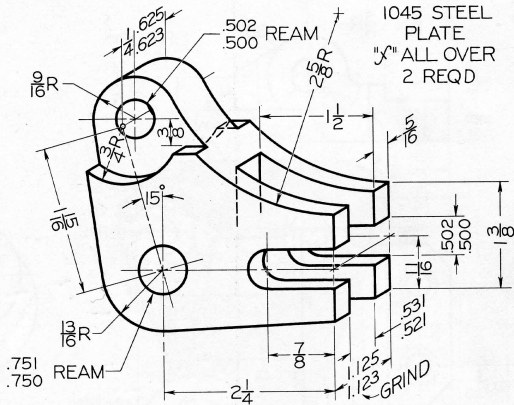

**Fig. 6-66 Toggle Lever (Layout A-3).\***

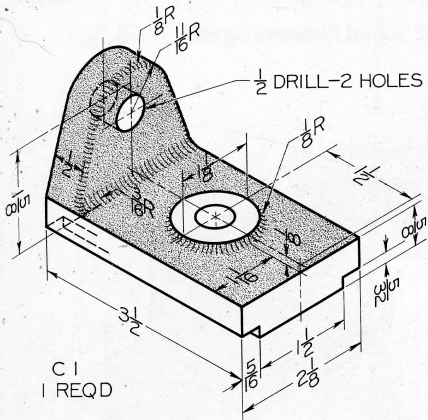

**Fig. 6-67 Cut-off Holder (Layout A-3).\***

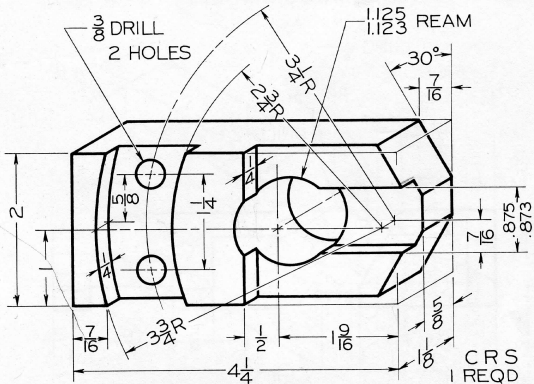

**Fig. 6-68 Index Slide (Layout A-3).\***

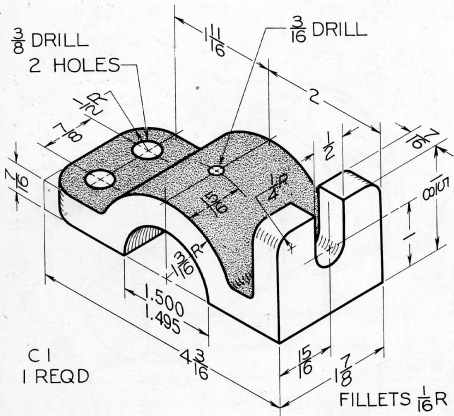

**Fig. 6-69 Frame Guide (Layout A-3).\***

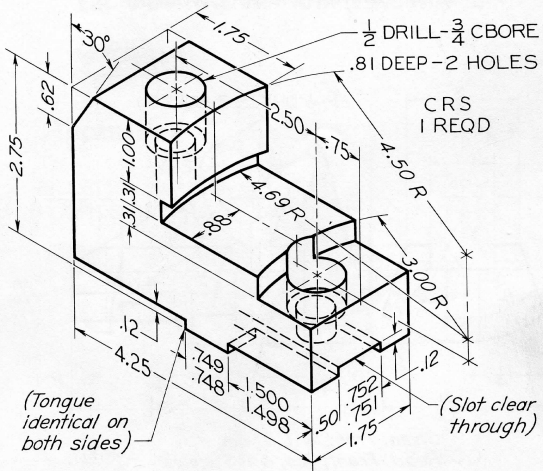

**Fig. 6-70 Chuck Jaw (Layout A-3).\***