

Fig. 6-59 Bearing (Layout A-3).*

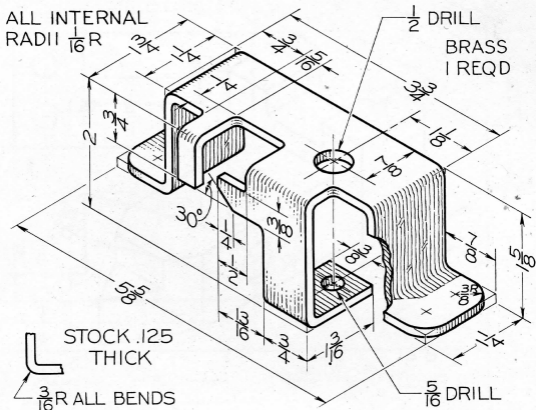

Fig. 6-60 Holder Clip (Layout A-3).*

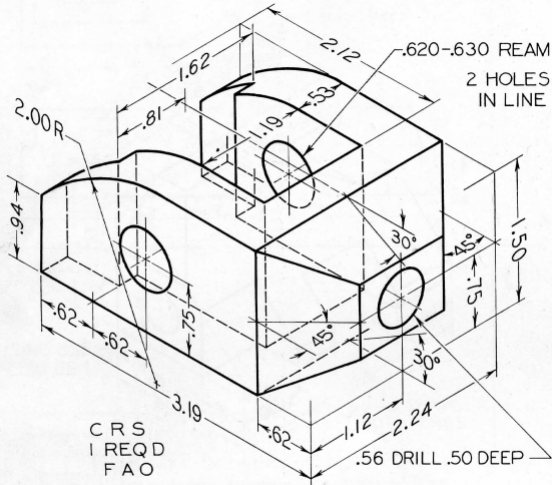

Fig. 6-61 Cam (Layout A-3).*

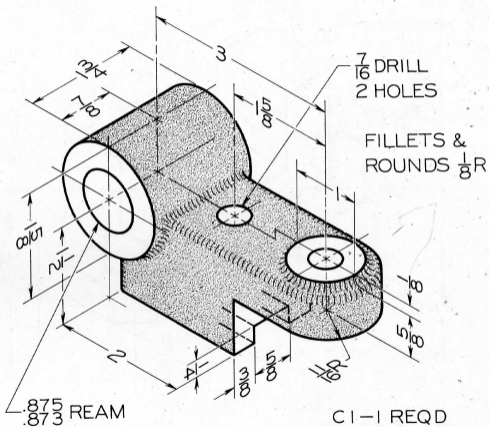

Fig. 6-62 Index Arm (Layout A-3).*

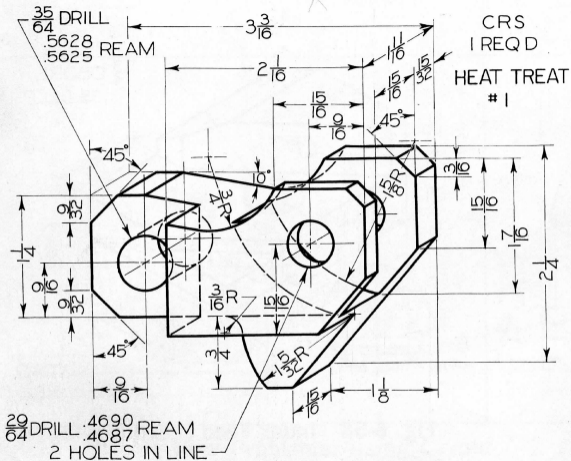

Fig. 6-63 Roller Lever (Layout A-3).*

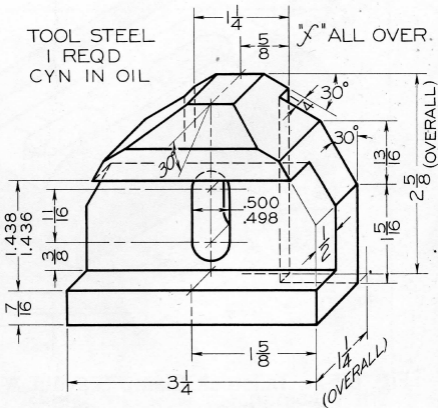

Fig. 6-64 Support (Layout A-3).*