

Fig. 6-53 Safety Key (Layout A-3).*

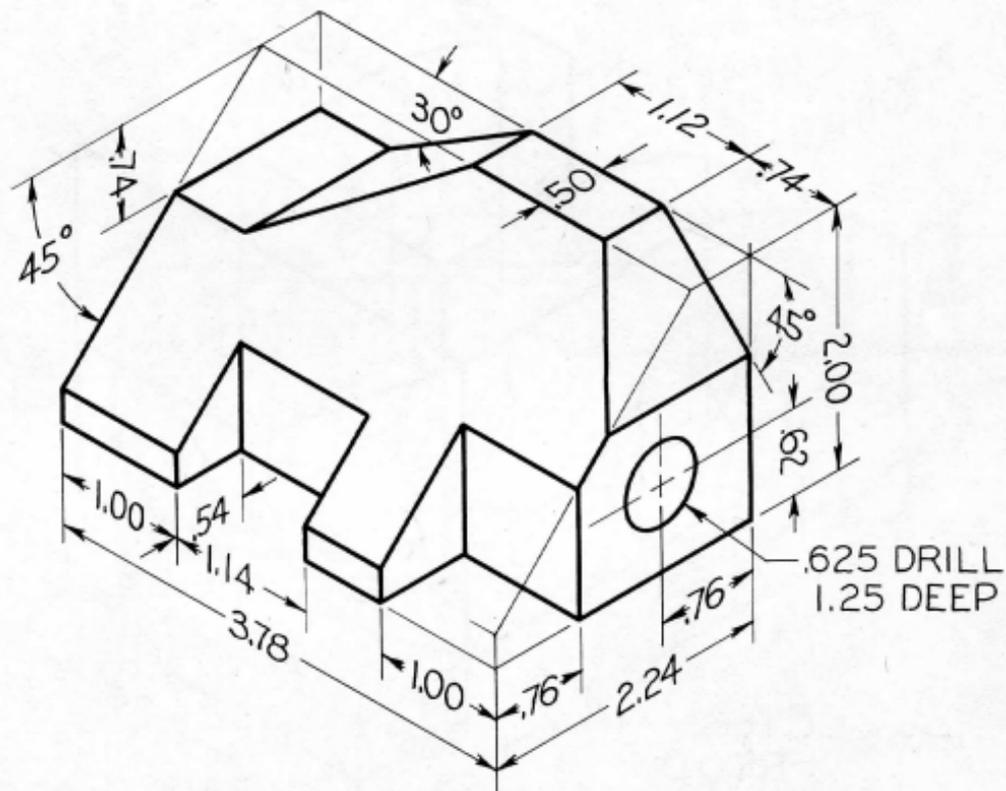

Fig. 6-56 Tool Holder (Layout A-3).*

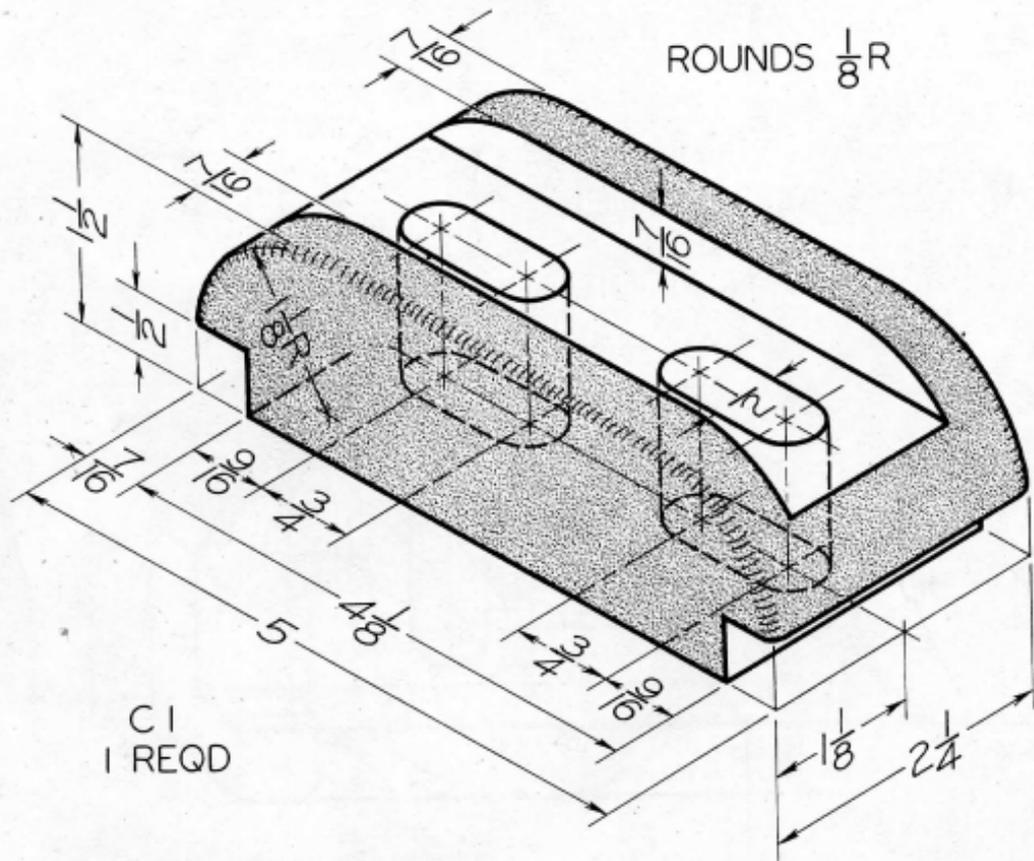

Fig. 6-57 Tailstock Clamp (Layout A-3).*

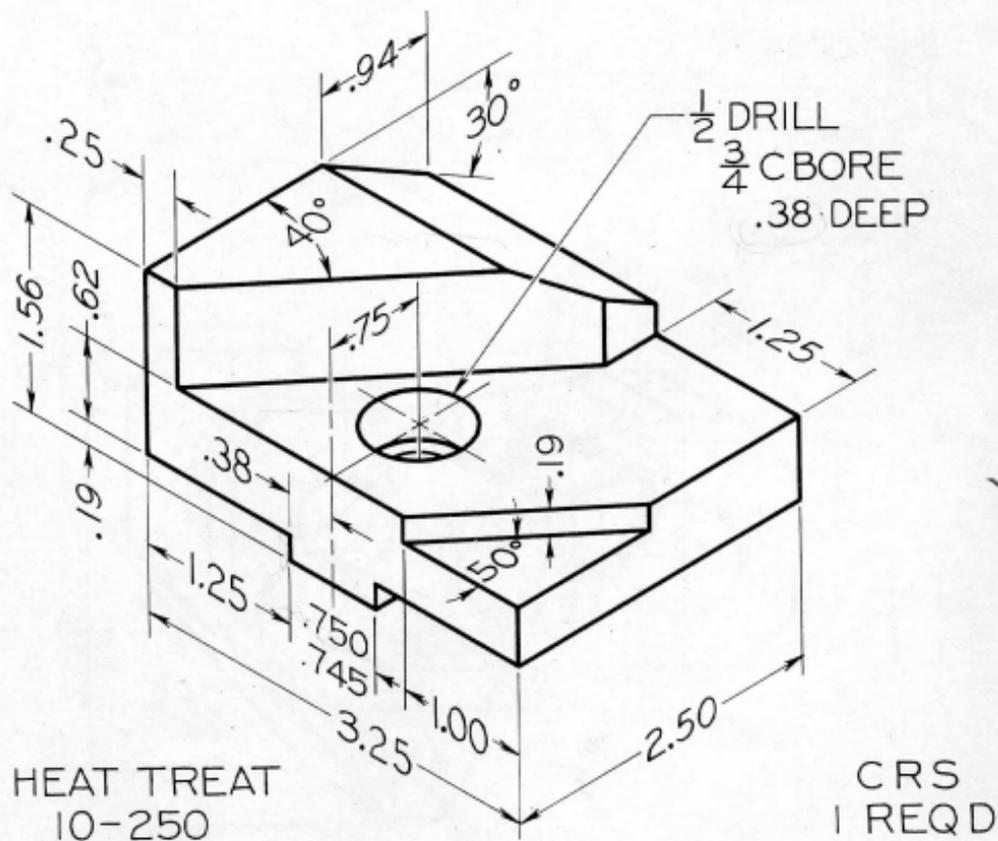

Fig. 6-58 Index Feed (Layout A-3).*