

Given: Front, left-side, and bottom views, and partial removed section.

Required: Front view in full section, top view, and right-side view in half section on A-A. Draw half size on Size C sheet.

Fig. 14-40 Spindle Housing.

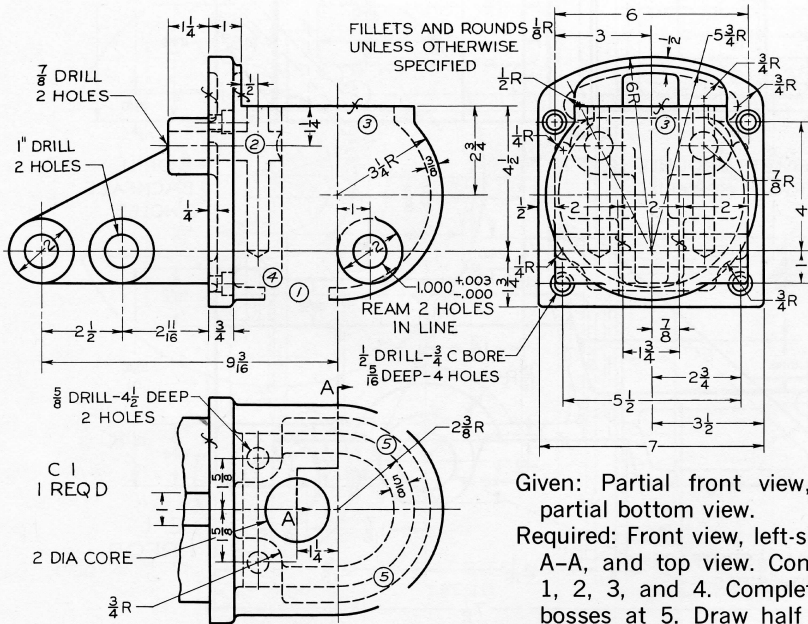

Given: Partial front view, right-side view, and partial bottom view.

Required: Front view, left-side view in half Section A-A, and top view. Construct intersections at 1, 2, 3, and 4. Complete the visible lines for bosses at 5. Draw half size on Size C sheet.

Fig. 14-41 Gear Change Lever Bracket.